

14 DOOR THRESHOLD SILL DETAIL
SCALE: 1 1/2" = 1'-0"

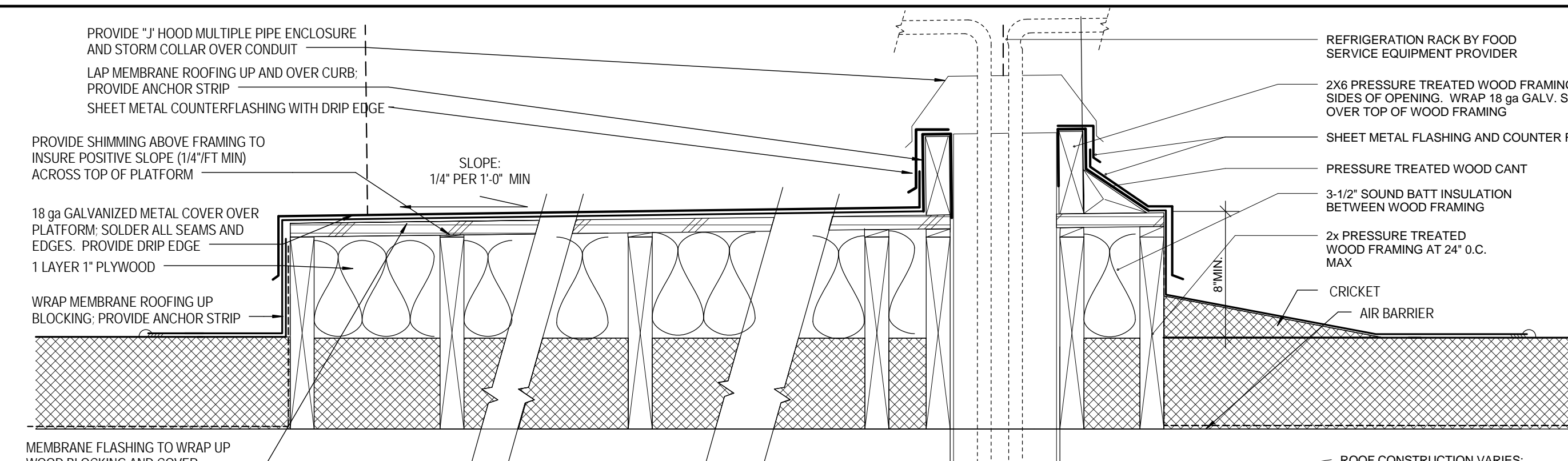

15 MECHANICAL EQUIPMENT PLATFORM FOR CONDENSING UNITS AND COMPRESSOR
SCALE: 1 1/2" = 1'-0"

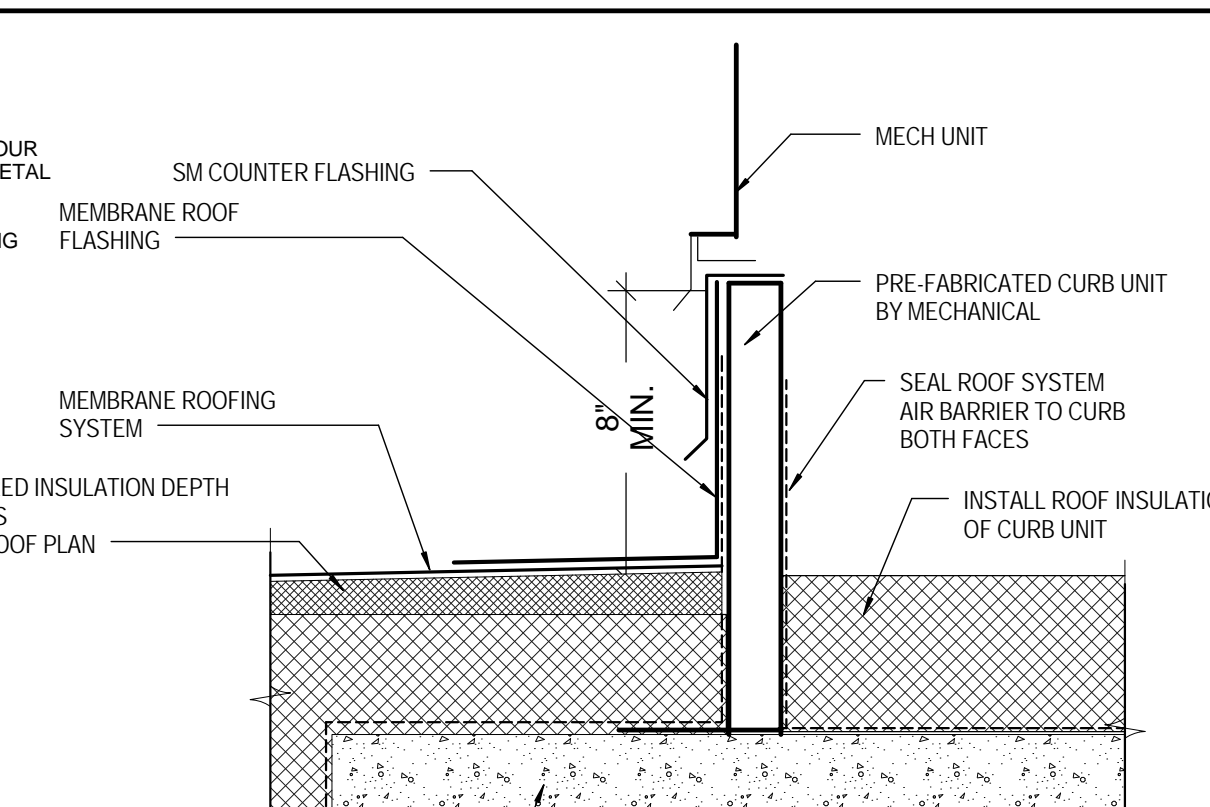

16 AHU MECH. CURB
SCALE: 1 1/2" = 1'-0"

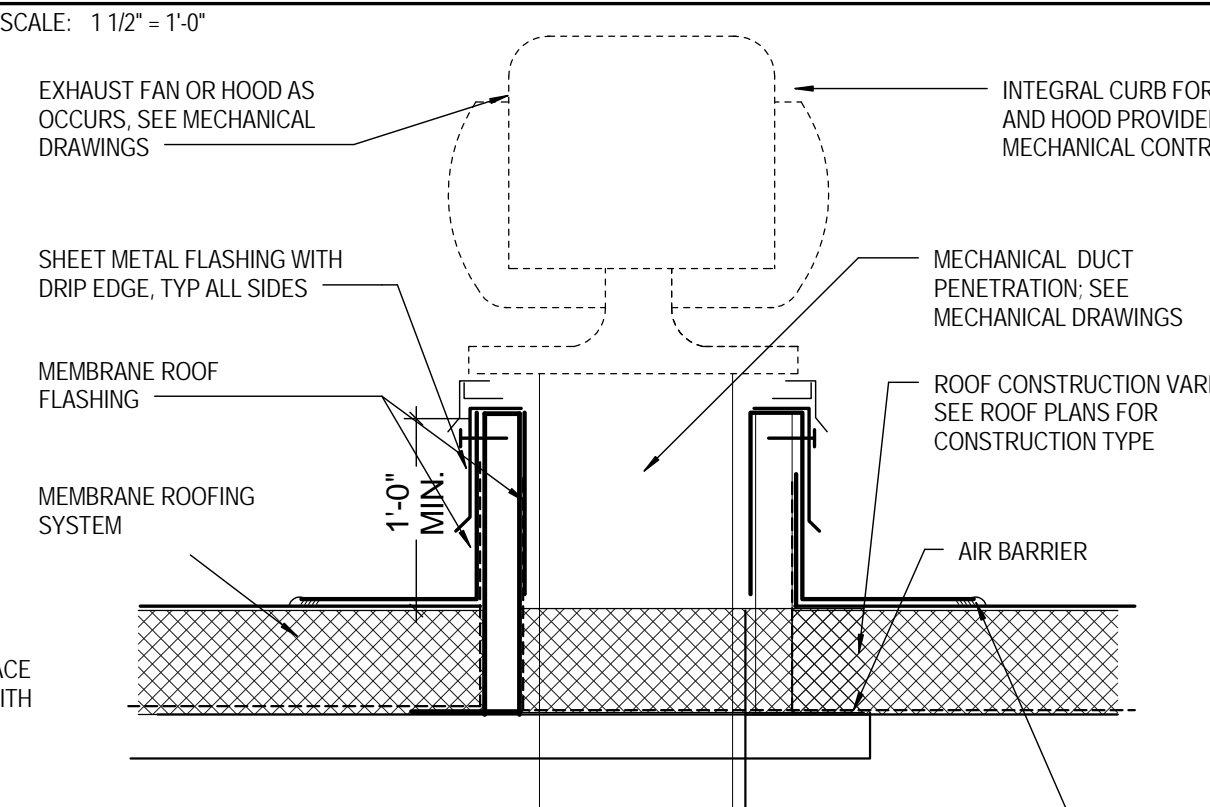

26 FAN AND HOOD CURB/FLASHING DETAIL
SCALE: 1" = 1'-0"

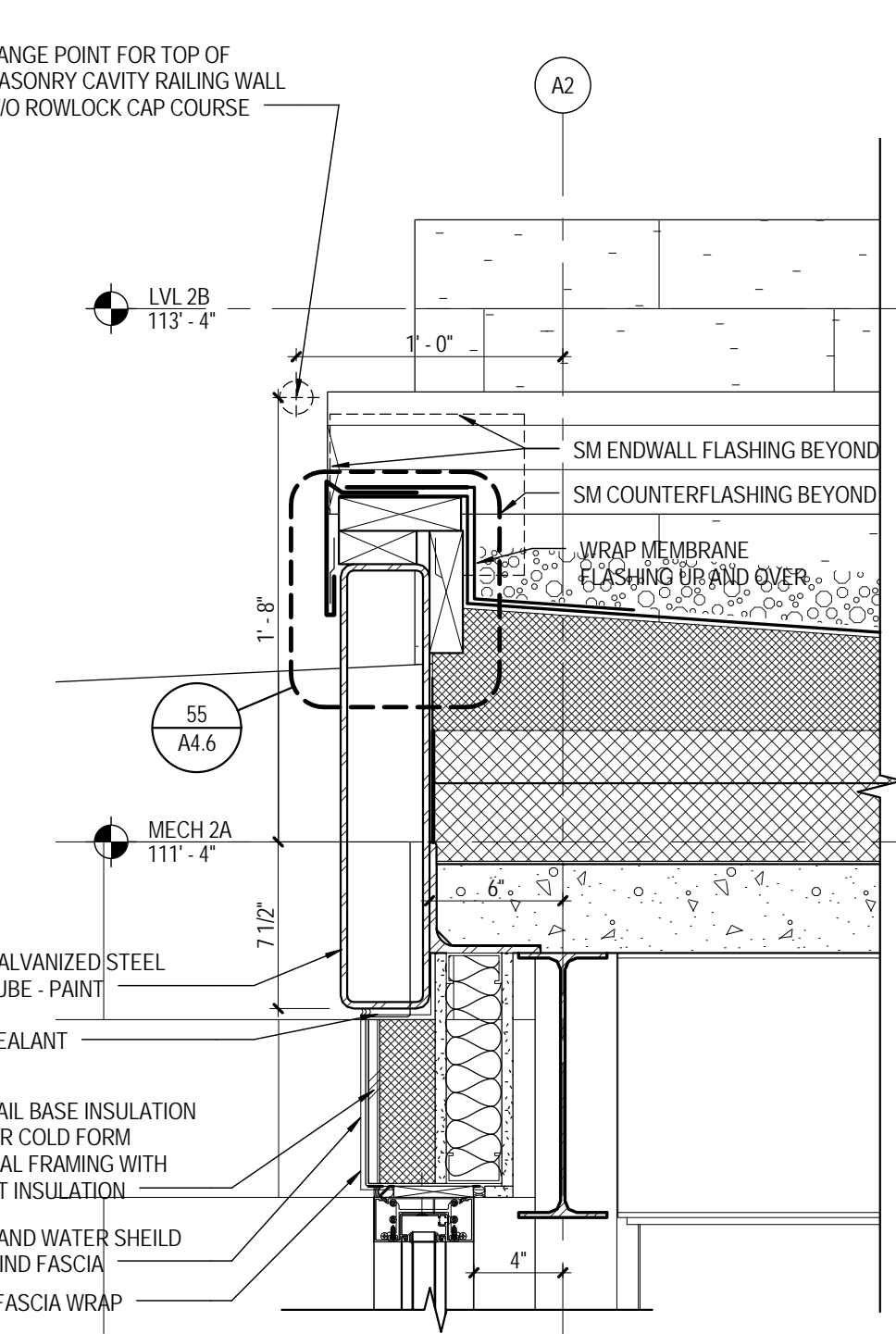

31 ROOF EDGE DETAIL
SCALE: 1 1/2" = 1'-0"

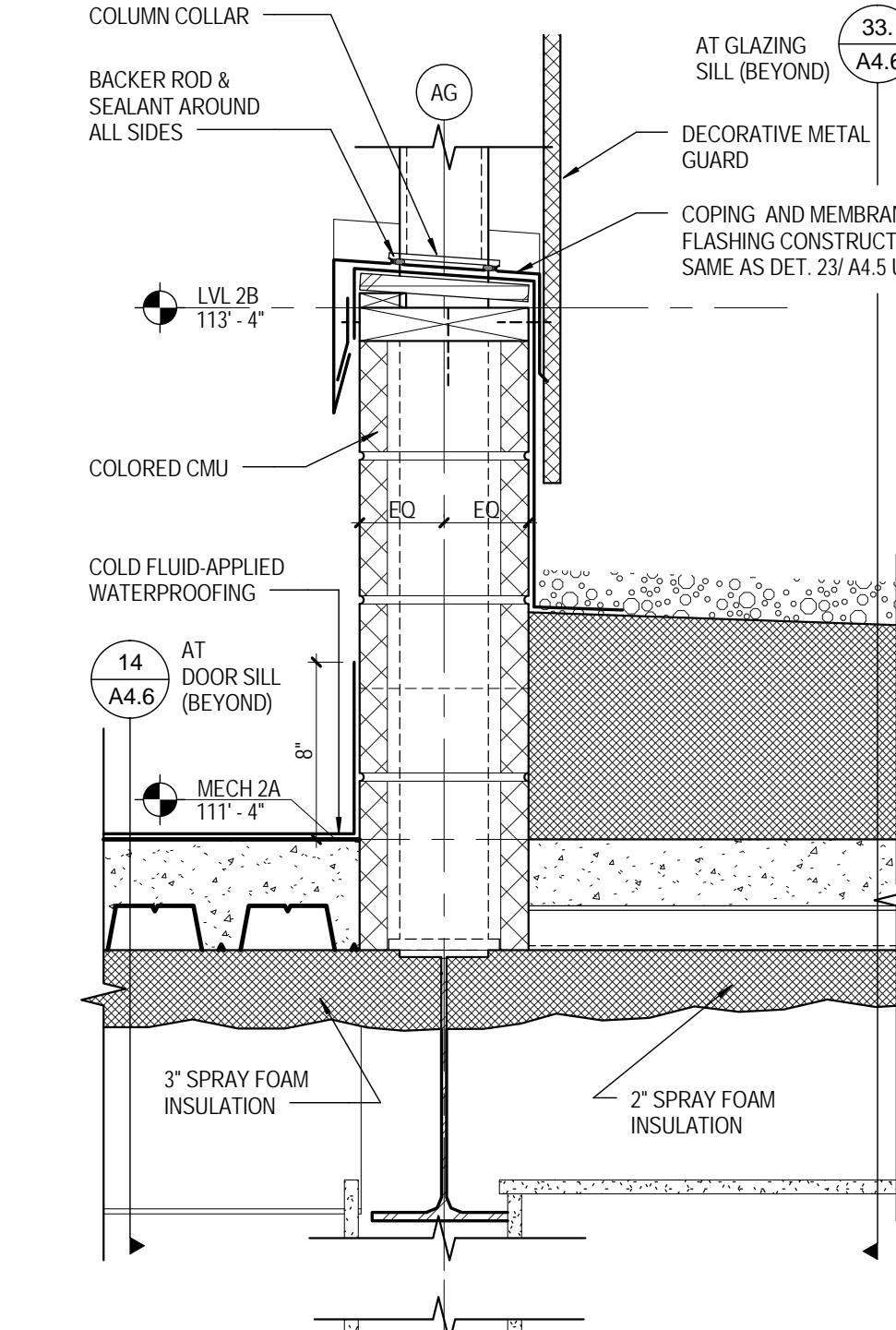

32 SECTION DETAIL
SCALE: 1 1/2" = 1'-0"

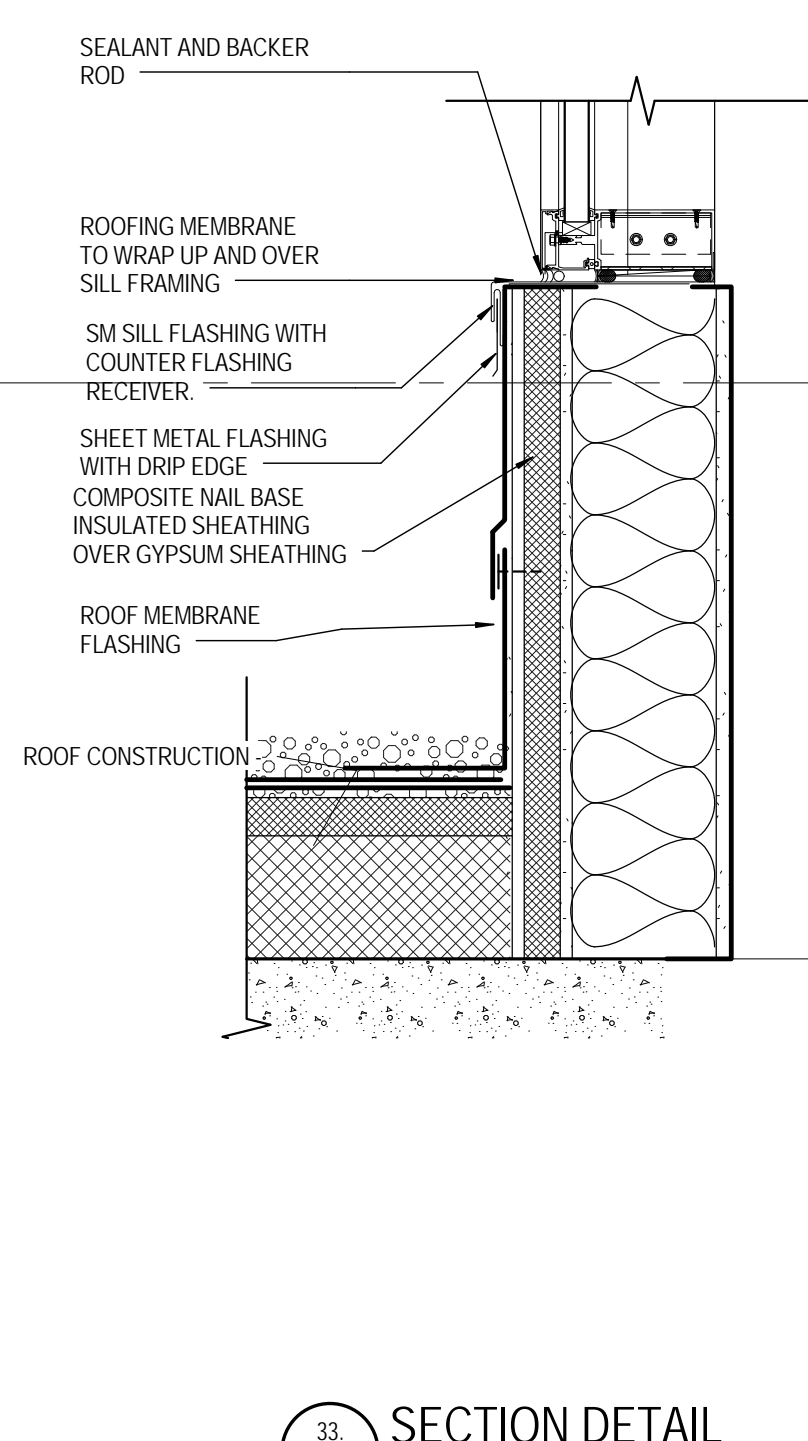

33 SECTION DETAIL
SCALE: 1 1/2" = 1'-0"

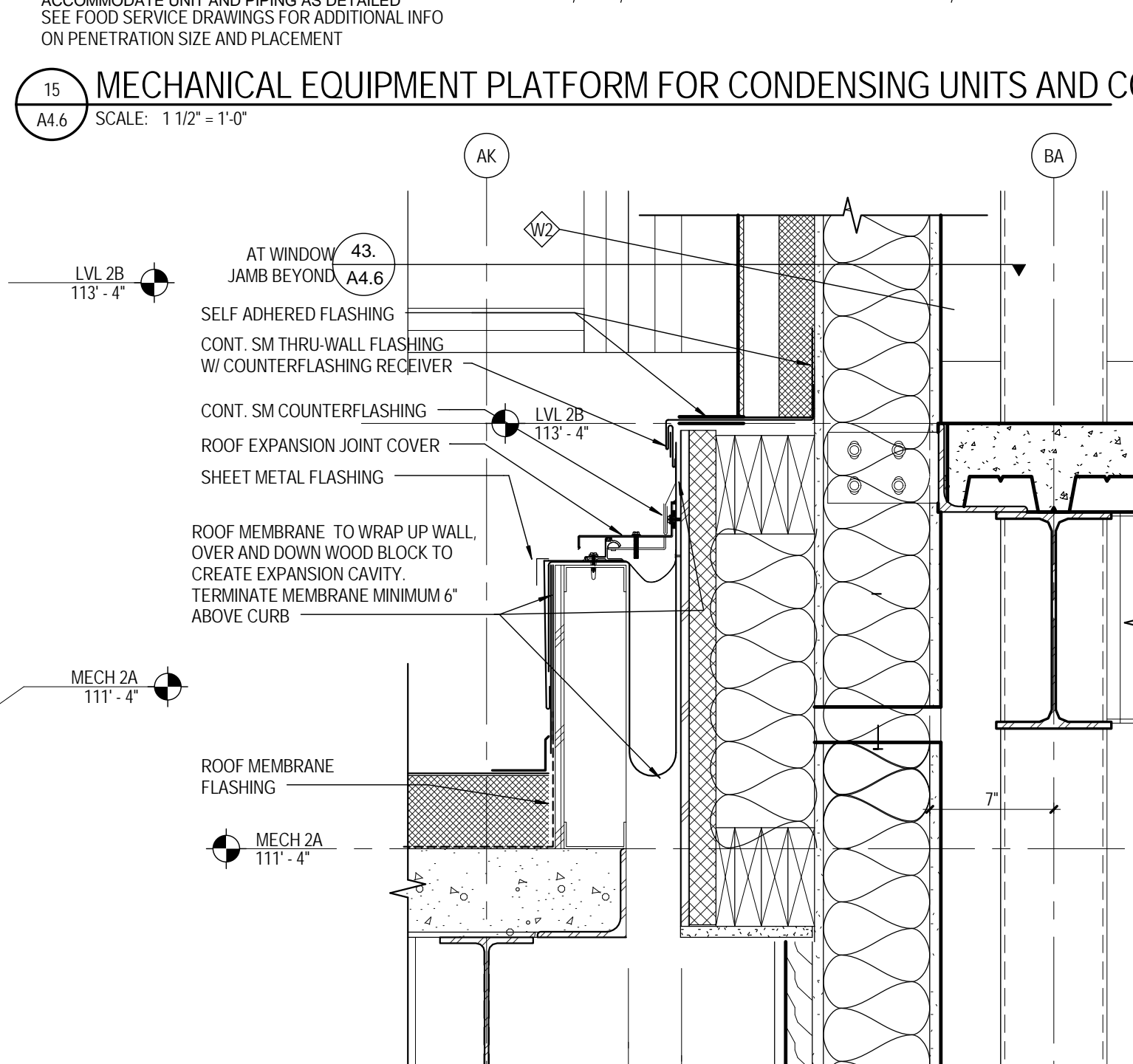

34 SECTION DETAIL AT EXPANSION JOINT
SCALE: 1 1/2" = 1'-0"

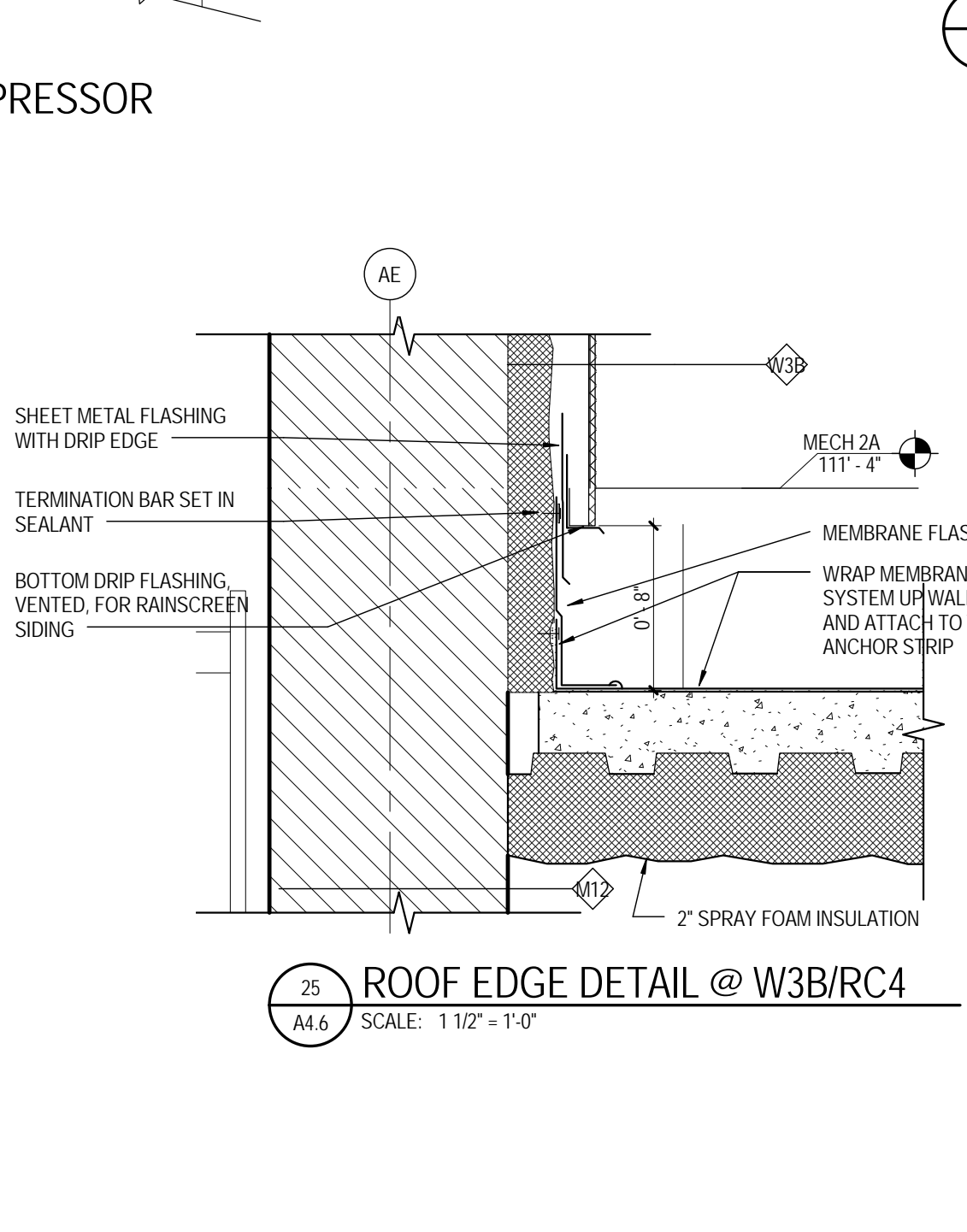

25 ROOF EDGE DETAIL @ W3B/RC4
SCALE: 1 1/2" = 1'-0"

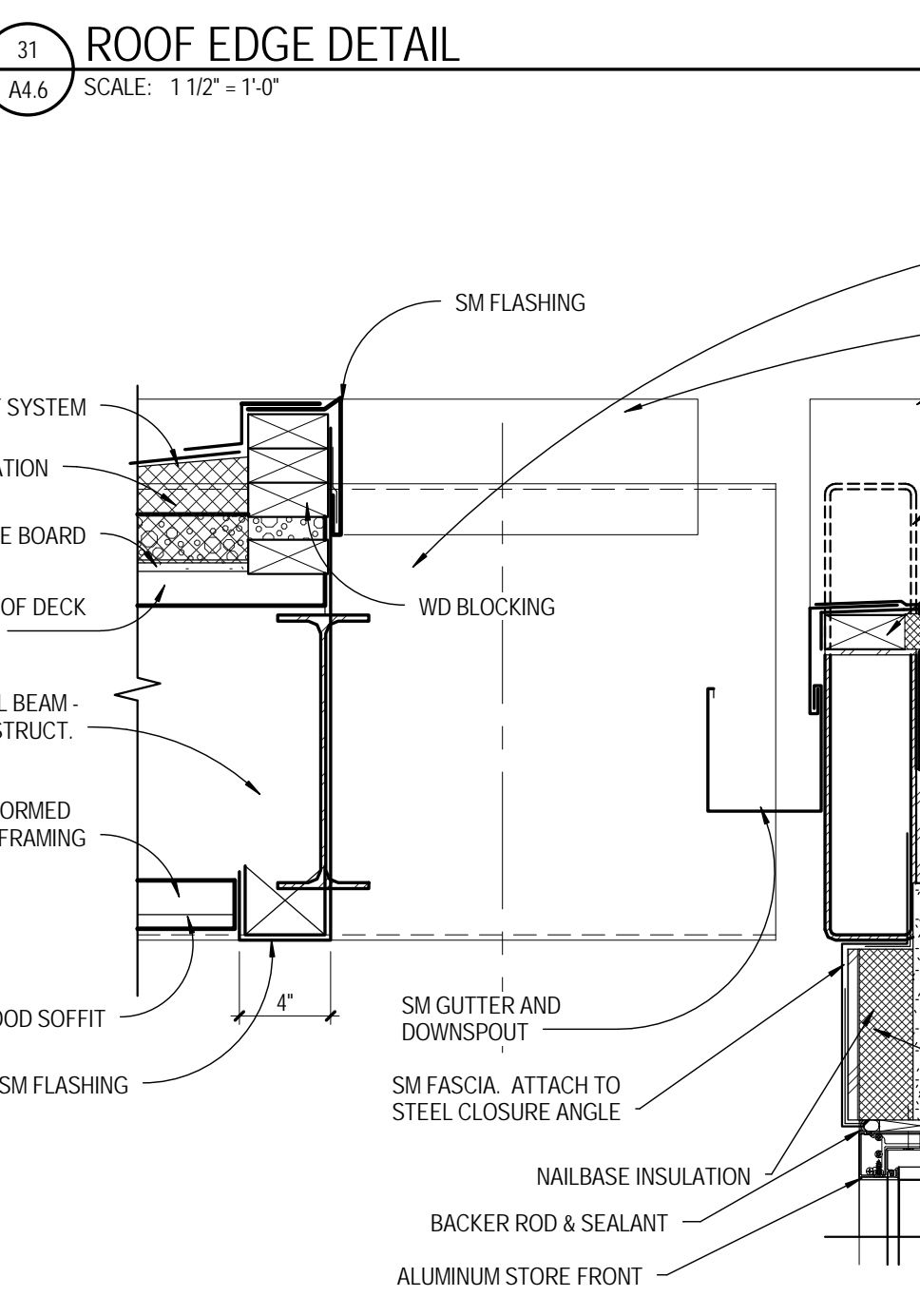

41 ROOF TRANSITION DETAIL @ EXP JNT
SCALE: 1 1/2" = 1'-0"

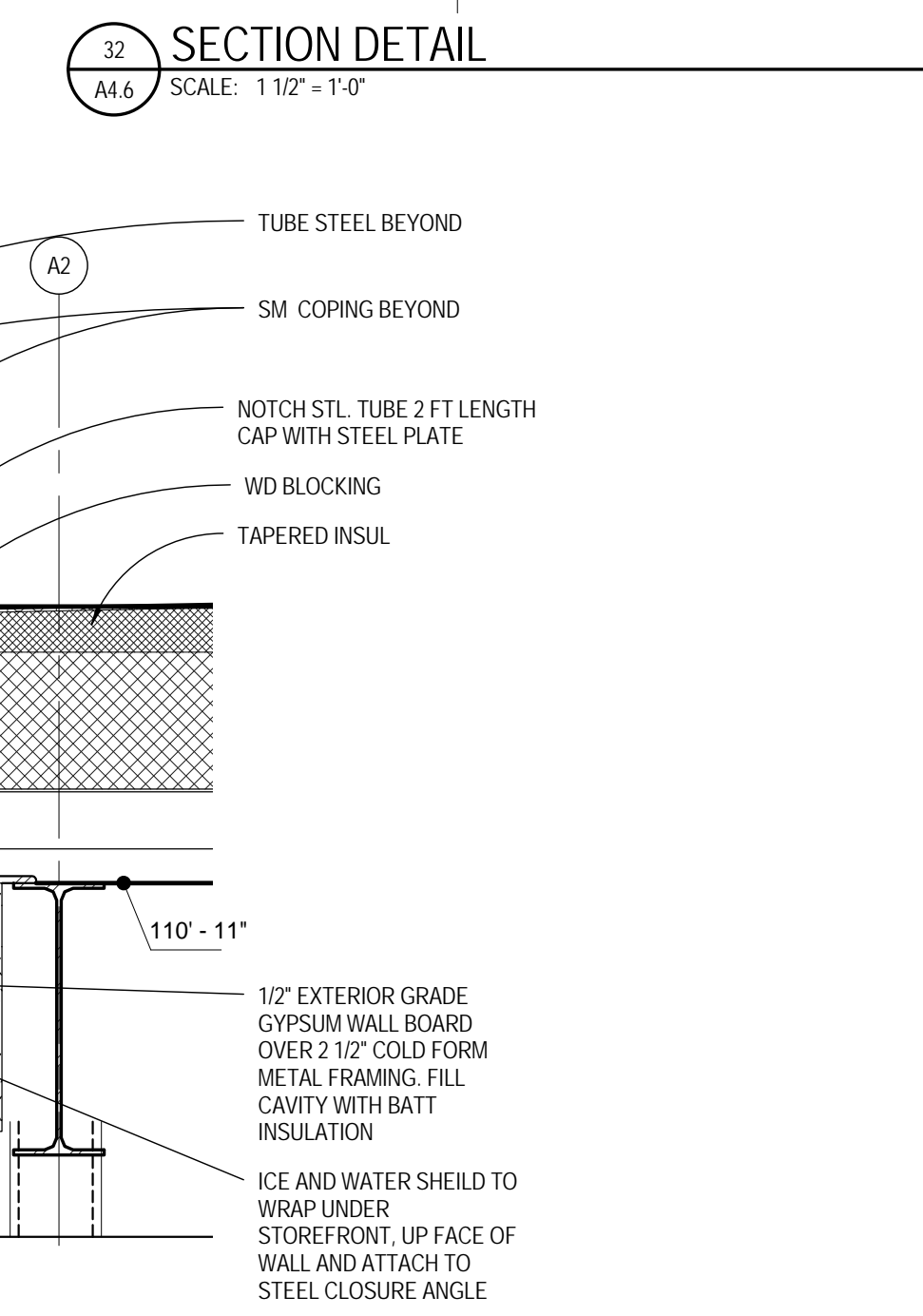

32 SECTION DETAIL
SCALE: 1 1/2" = 1'-0"

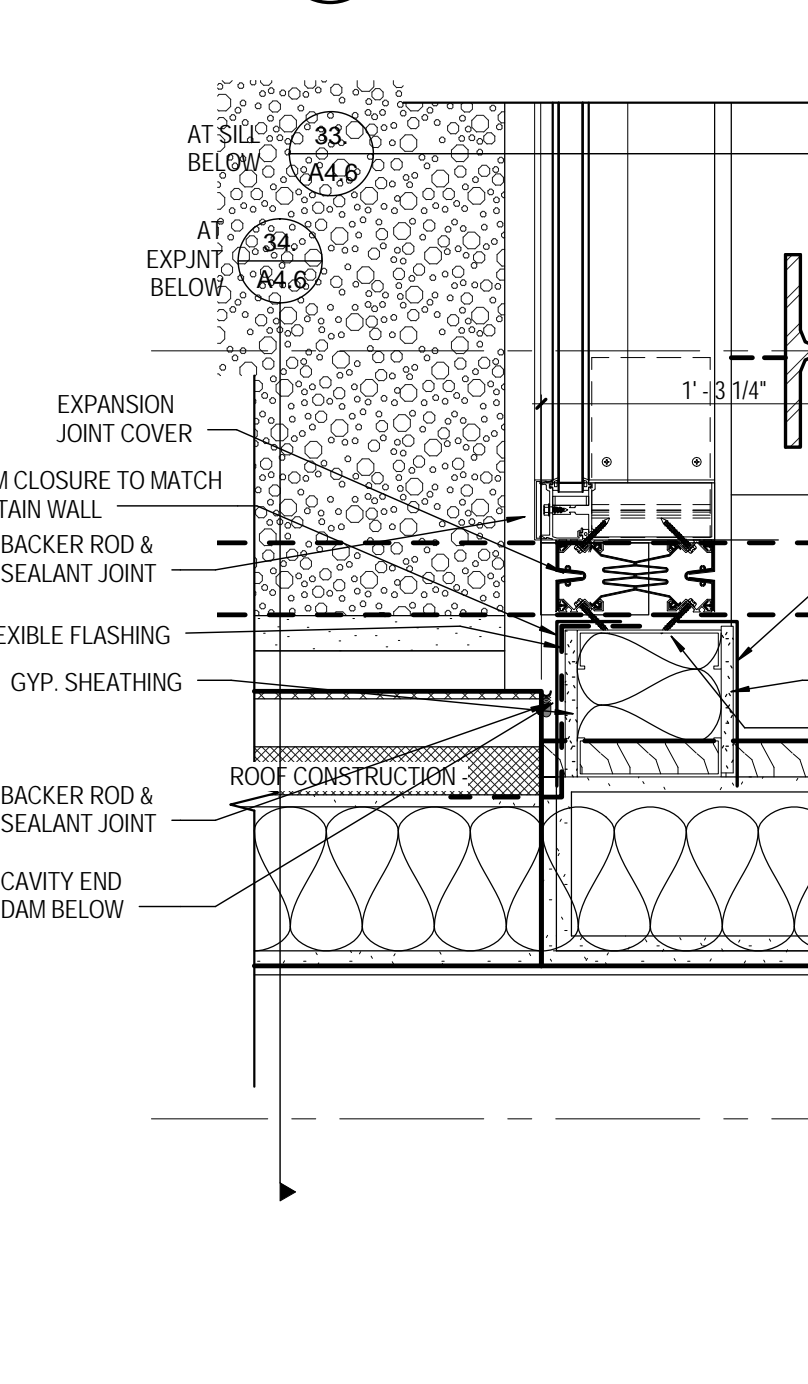

33 SECTION DETAIL
SCALE: 1 1/2" = 1'-0"

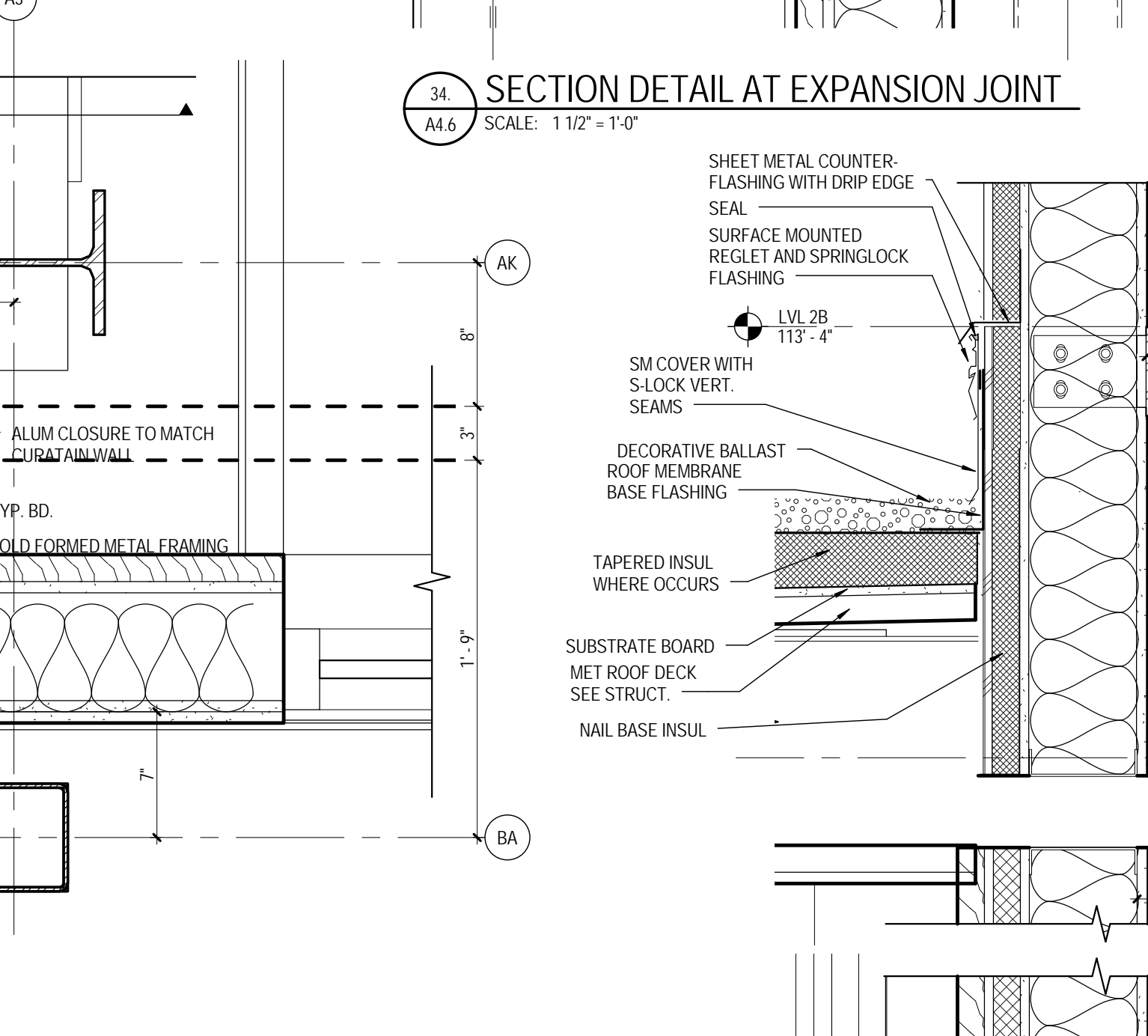

44 ROOFING DETAIL BEYOND EXPANSION JOINT
SCALE: 1 1/2" = 1'-0"

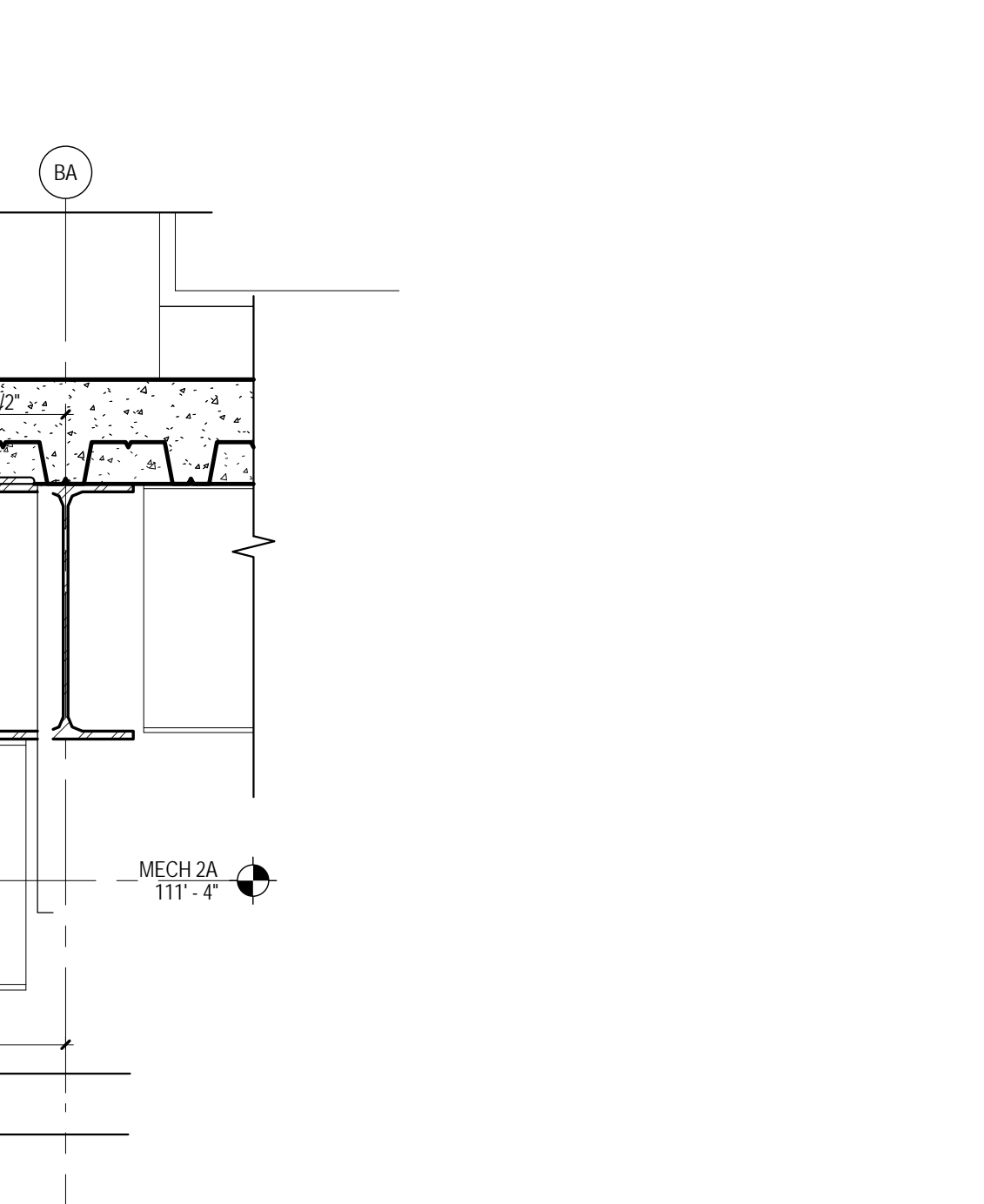

34 SECTION DETAIL
SCALE: 1 1/2" = 1'-0"

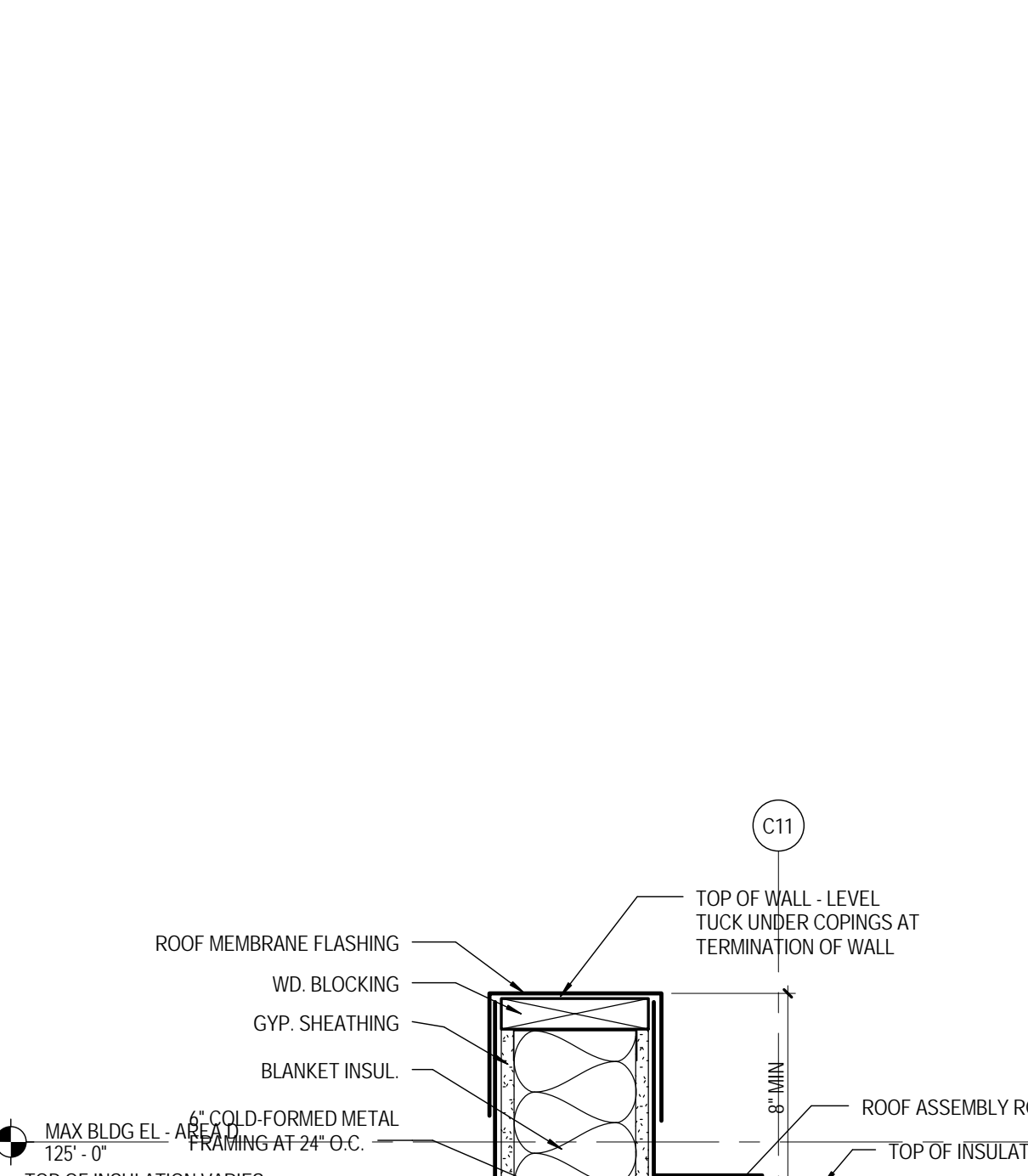

50 ROOF CURB TRANSITION DET.
SCALE: 1 1/2" = 1'-0"

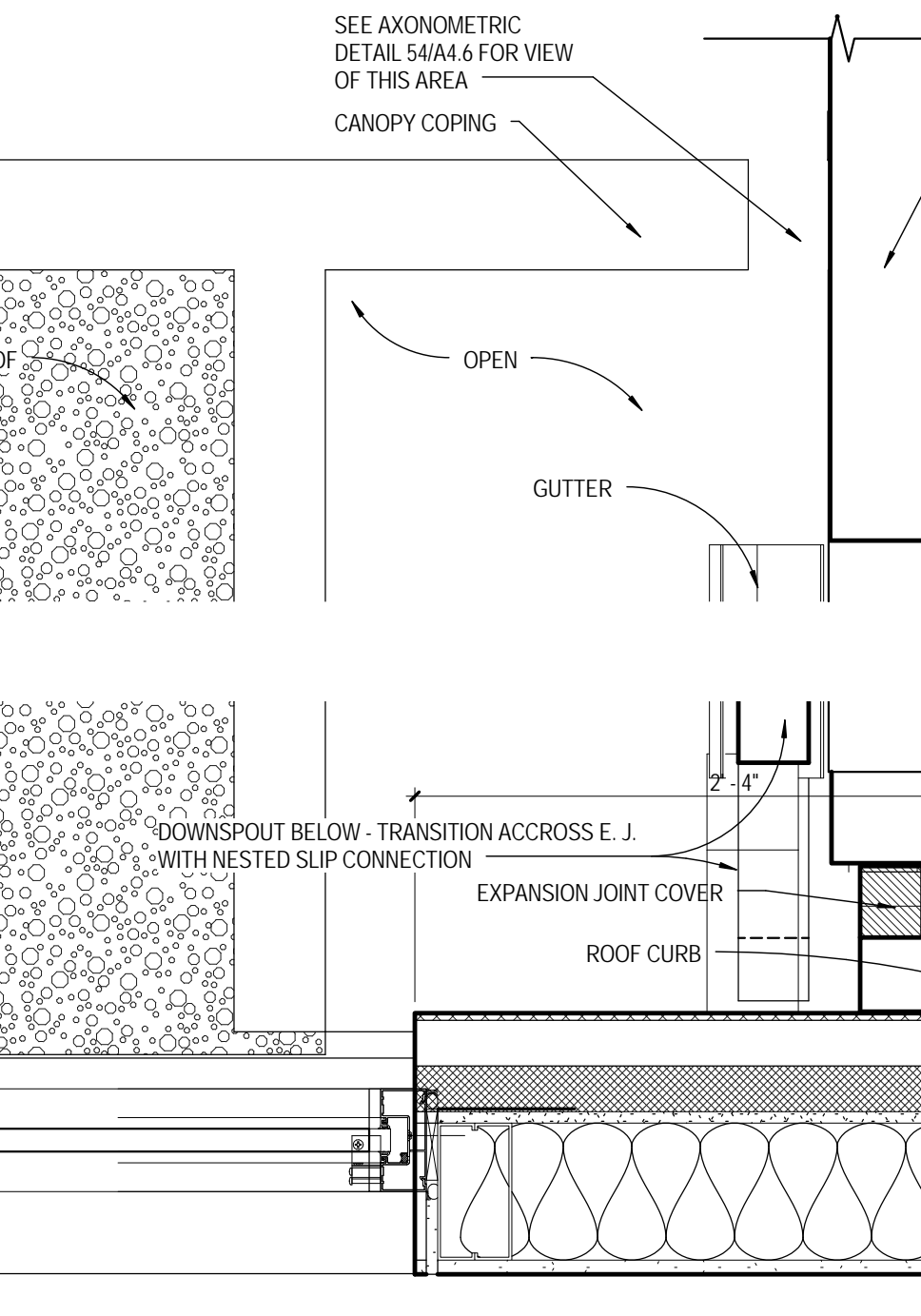

51 PLAN DETAIL AT E.J. TRANSITION AT CANOPY
SCALE: 1 1/2" = 1'-0"

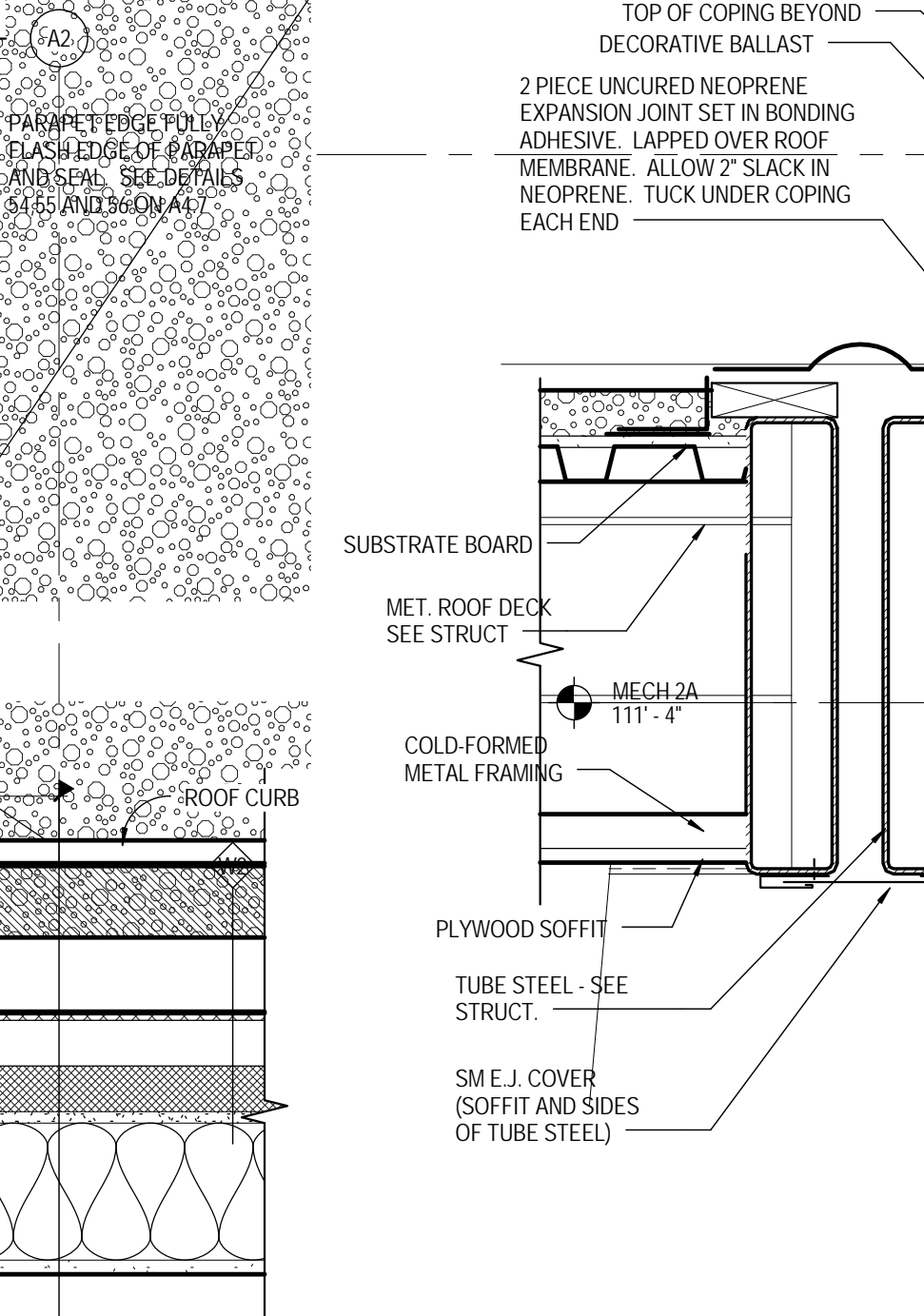

52 CANOPY E.J.
SCALE: 1 1/2" = 1'-0"

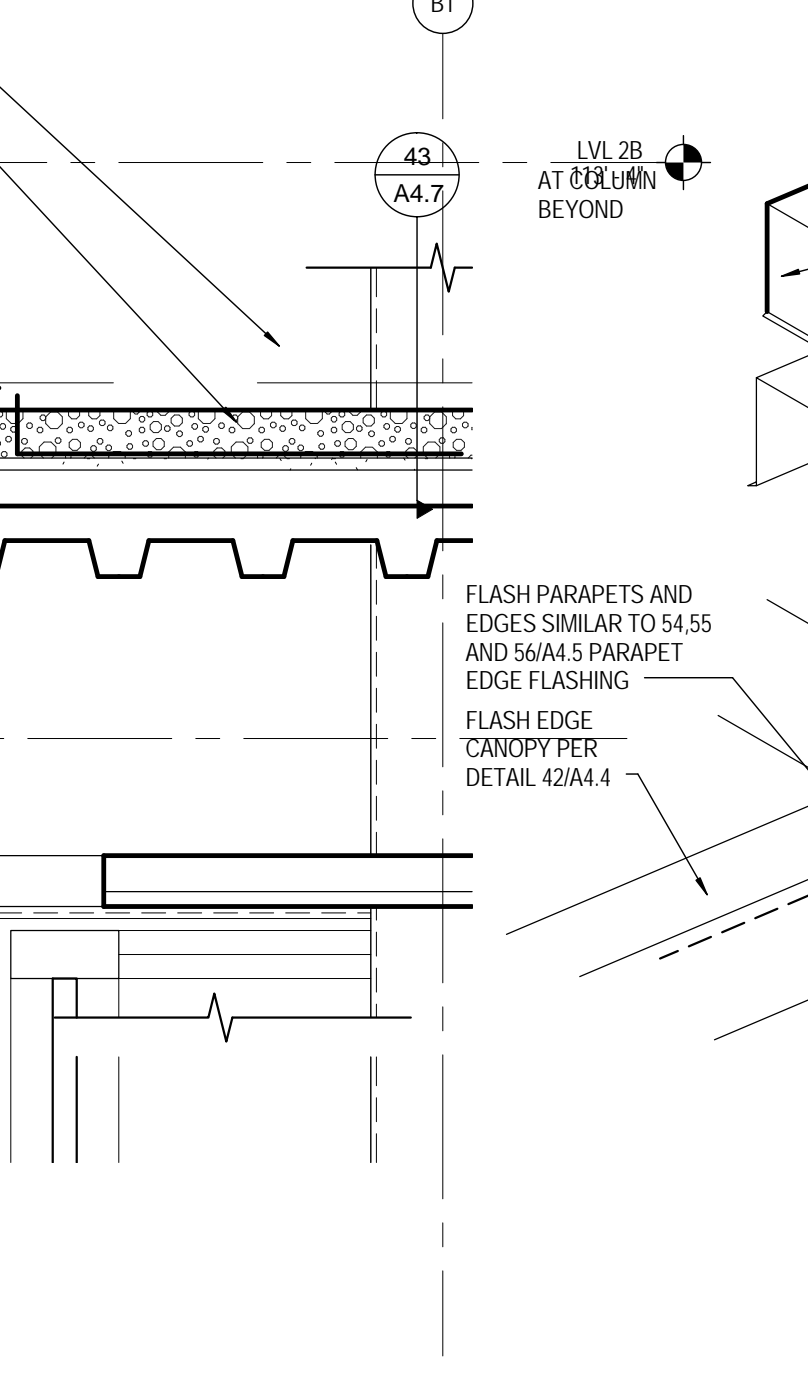

54 FLASHING AXONOMETRIC
SCALE: 3/8" = 1'-0"

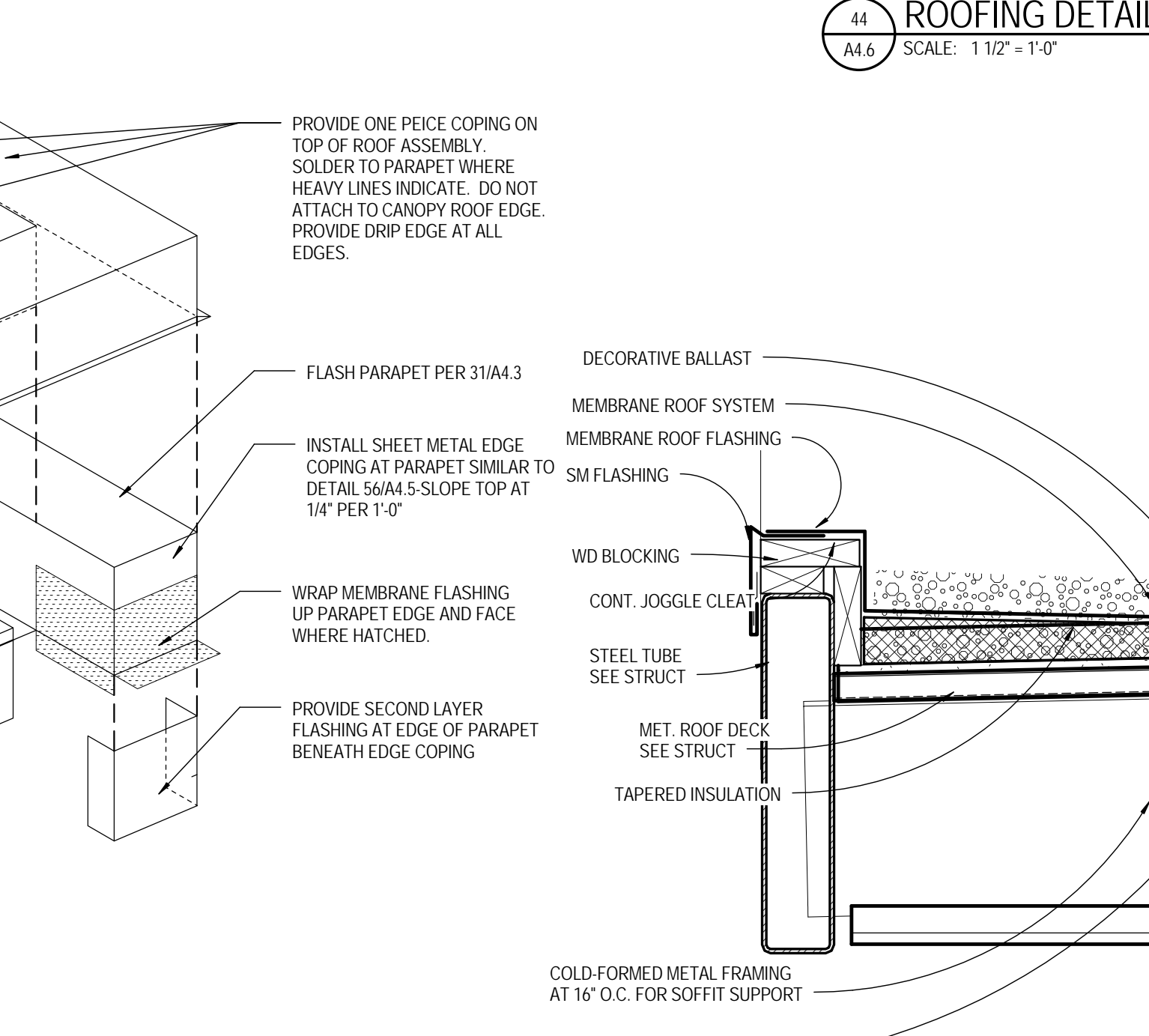

55 CANOPY EDGE DETAILS
SCALE: 1 1/2" = 1'-0"

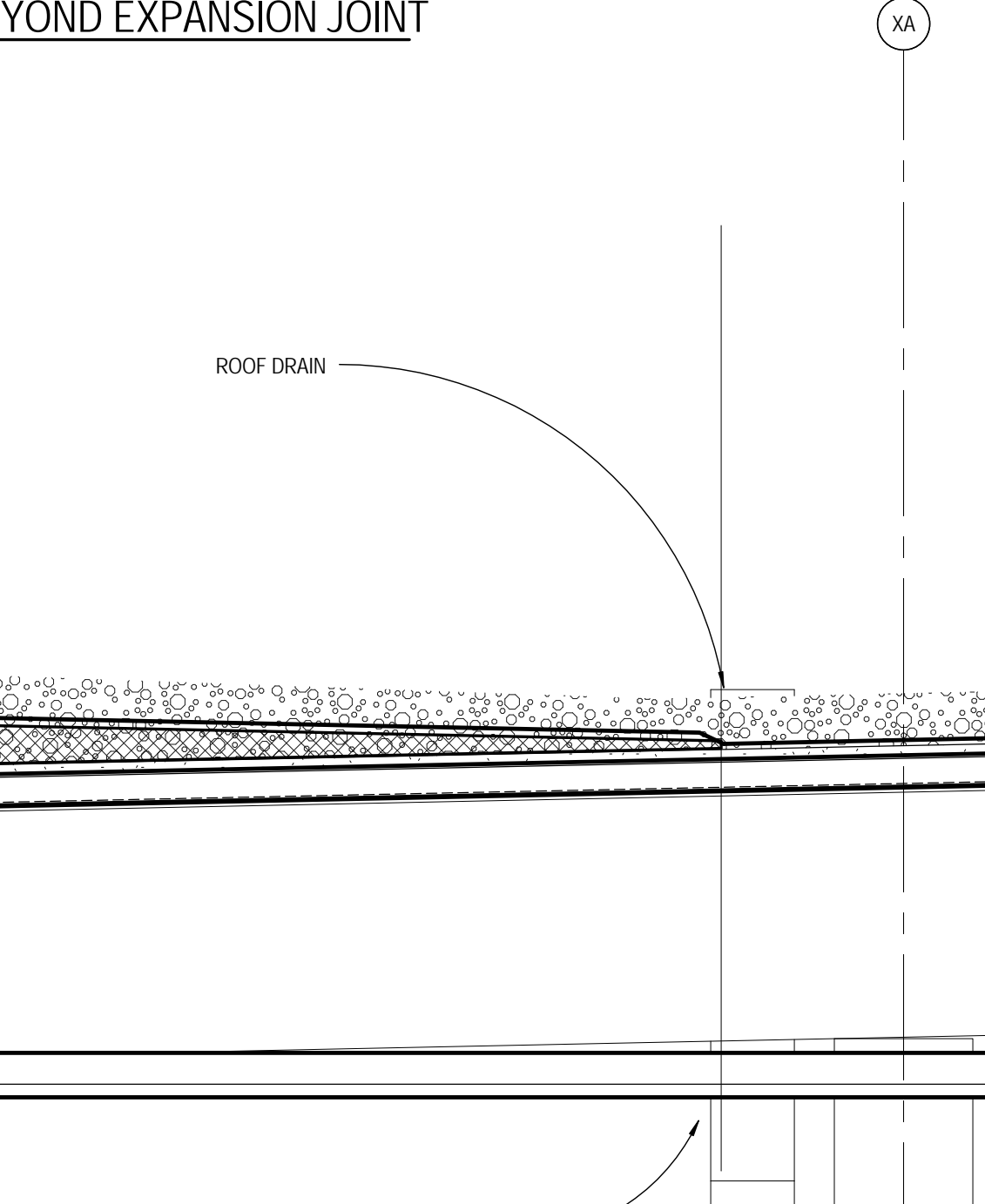

34 SECTION DETAIL
SCALE: 1 1/2" = 1'-0"

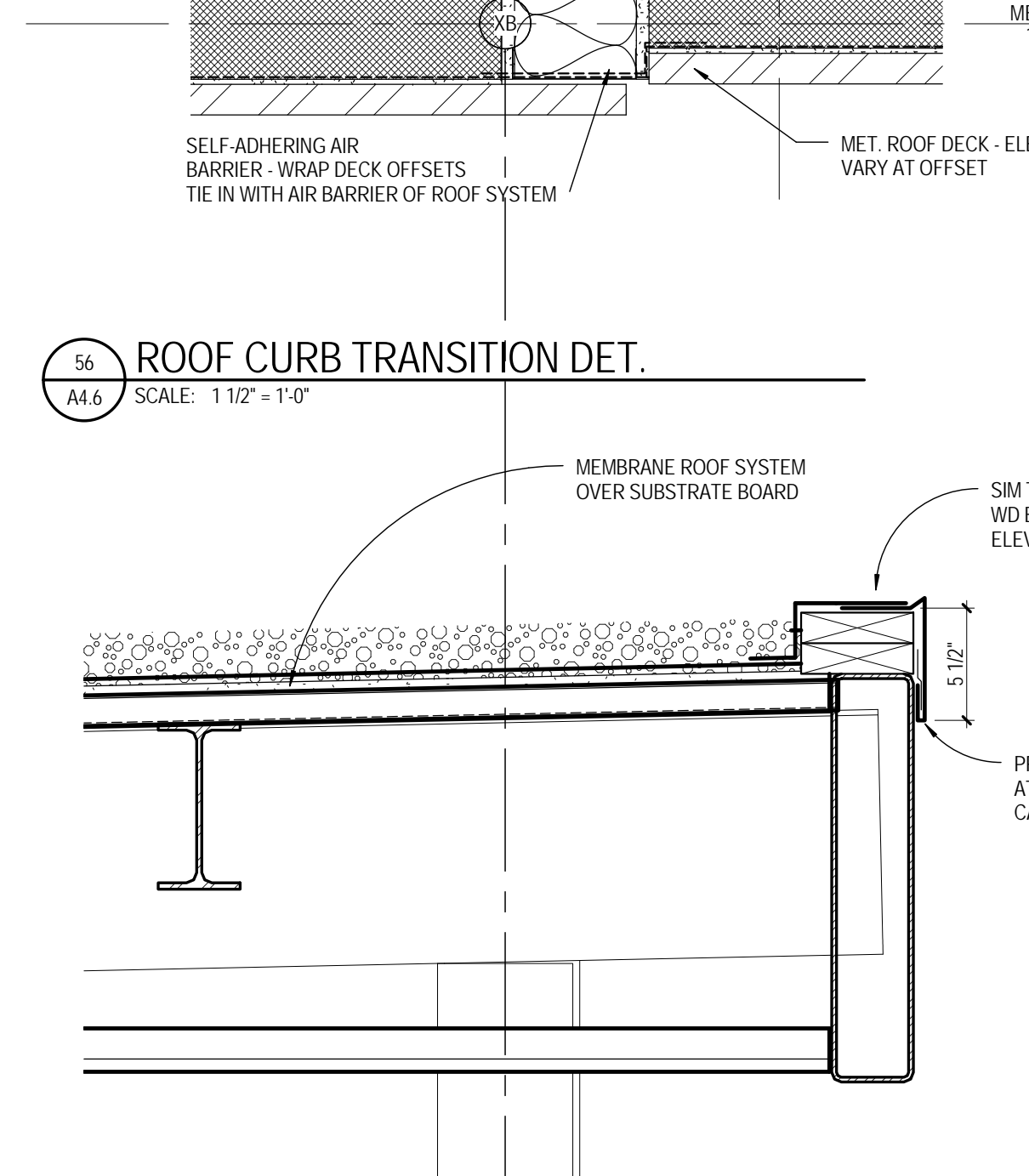

34 SECTION DETAIL
SCALE: 1 1/2" = 1'-0"